

GENERAL NOTES:

- 1) MAXIMUM FLOW RATE 50 G.P.M. (230 l/min)
- 2) INFLUENT TEMP.: 40° F (5° C) & GREATER
- 3) INFLUENT OIL SPECIFIC GRAVITY: < 0.95
- 4) EFFLUENT QUALITY: < 0.0016 oz/gal. (< 10mg/l) TEH
- 5) RECOMMENDED OIL STORAGE: 200 imp. gal. (910L)
- 6) SLUDGE CAPACITY: 12.75 cu. ft. (0.36 cu. m)
- 7) COALESCING MEDIUM: A.F.C. TWIN CARTRIDGE COALESCING PACKAGE
- 8) PIPING: $\phi 4"$ (100)PVC

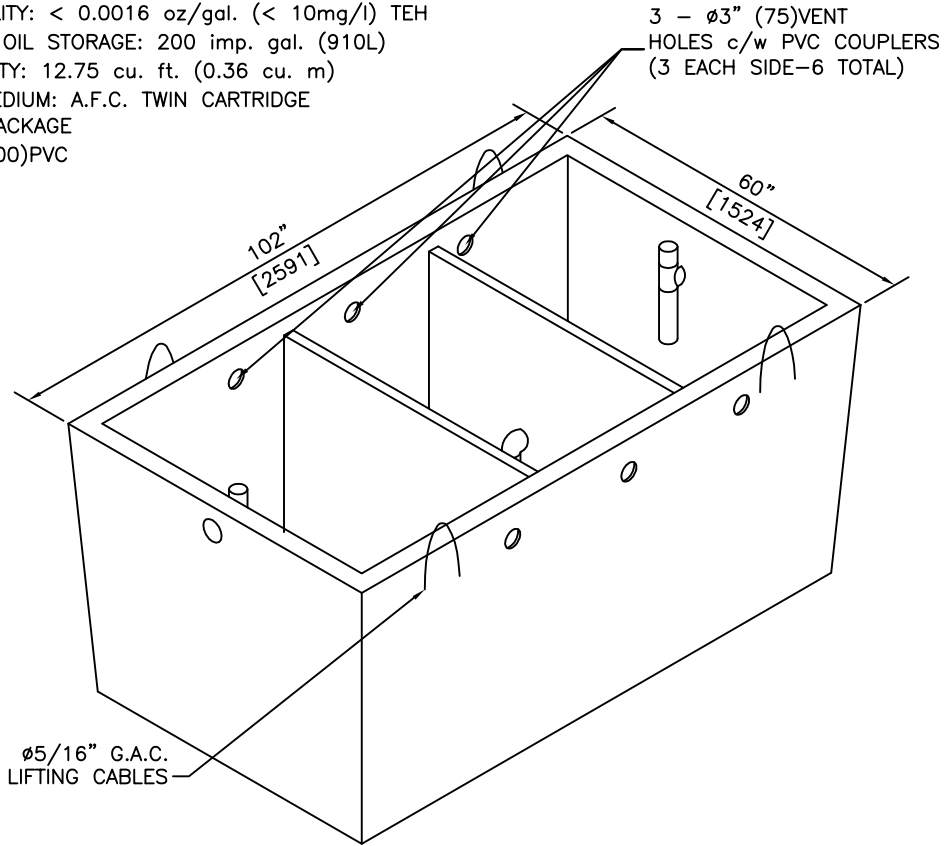

ISOMETRIC

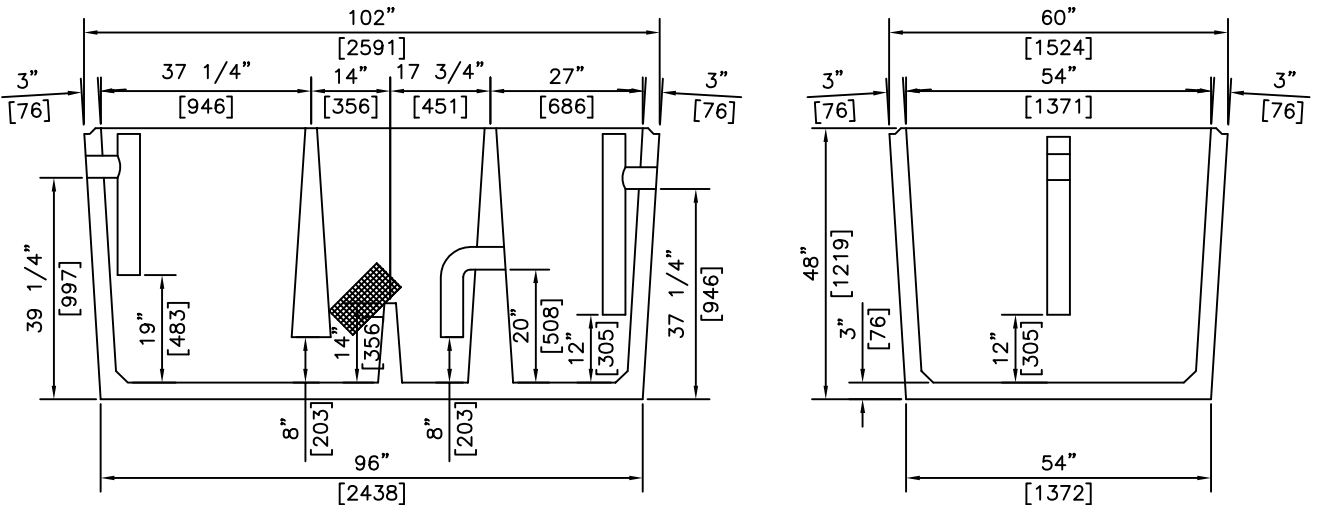

SECTIONS

NOTES:

US PATENT No 6,079,571
 CANADIAN PATENT No 2,252,307

AFC OIL/WATER SEPARATOR SPECIFICATIONS ARE SUBJECT TO LIMITATIONS OF LIABILITY

REVISED: SEPT 25 2014

A.F.C. AMERICAN FORCECRETE OF CANADA Inc.	3891 Irvine Road LAKE COUNTRY, B.C. V4V 2G4 PH: (250) 548-0056 FX: (250) 765 0820	BY: PKR DATE: FEB 1 06 SCALE: NTS	AFC OIL/WATER SEPARATOR - 50GPM (230 LITRE)	ITEM NO. 1601